

# pFlow

## Ultrasonic Flowmeter P118i





## About P118i

P118i Portable Ultrasonic Flowmeter enables the user to do flow measurement checks at many points in a flow process without the need for a permanent installation.

This ultrasonic flowmeter adopts Gentos unique PICOFLY time measurement technology, which could make the resolution reach to 10 picoseconds (0.01 nanosecond). It realizes the high response and high accuracy ultrasonic measurement technology and application.

Comparing with other traditional flowmeter or ultrasonic flowmeter, it has distinctive features such as high precision, high reliability, high capability and low cost, the flowmeter features other advantages:

PICOFLY technology designed.

Less hardware components, low voltage broadband pulse transmission, low consumption power. Clear, user-friendly menu selections make flowmeter simple and convenient to use.

Daily, monthly and yearly totalized flow.

Parallel operation of positive, negative and net flow totalizes with scale factor (span) and 7 digit display, while the output of totalize pulse and frequency output are transmitted via relay and open collector.



## Applications



## Specification

Performance specifications	
Flow range	$\pm 0.03 \sim \pm 40$ ft/s ( $\pm 0.01 \sim \pm 12$ m/s)
Accuracy	$\pm 0.5\%$ of measured value
Repeatability	0.15%.
Linearity	$\pm 0.5\%$ .
Pipe Size	Clamp-on: 0.6" ~ 240" (15mm ~ 6000mm)
Function specifications	
Outputs	Analog output: 4~20mA, Max 750 $\Omega$ .
SD card	Storage: 2GB; Max: 512 files; Interval: 1 ~ 60 seconds.
Power supply	rechargeable Lithium Battery Power ( continuous operation of mainbattery 10 hours ).
Keypad	Tactile Keys.
Display	3.5 inch TFT color screen( 320 × 240 ), backlit LCD.
Temperature	Transmitter: 14°F ~ 122°F (-10°C ~ 50°C) Transducer: -40°F ~ 176°F (-40°C ~ 80°C, standard)
Humidity	0 to 99% RH, non-condensing
Physical specifications	
Transmitter	NEMA13 ( IP54 ).
Transducer	Encapsulated design, IP68; Standard cable length: 5m.
Weight	Transmitter: approximately 1.0kg.

## Wiring Diagram

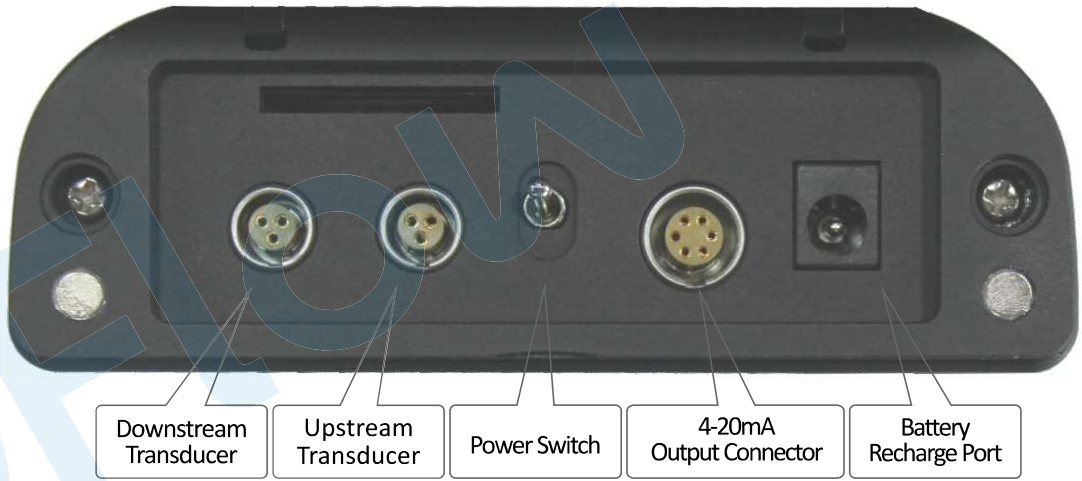

## Transmitter Dimensions

### Transmitter

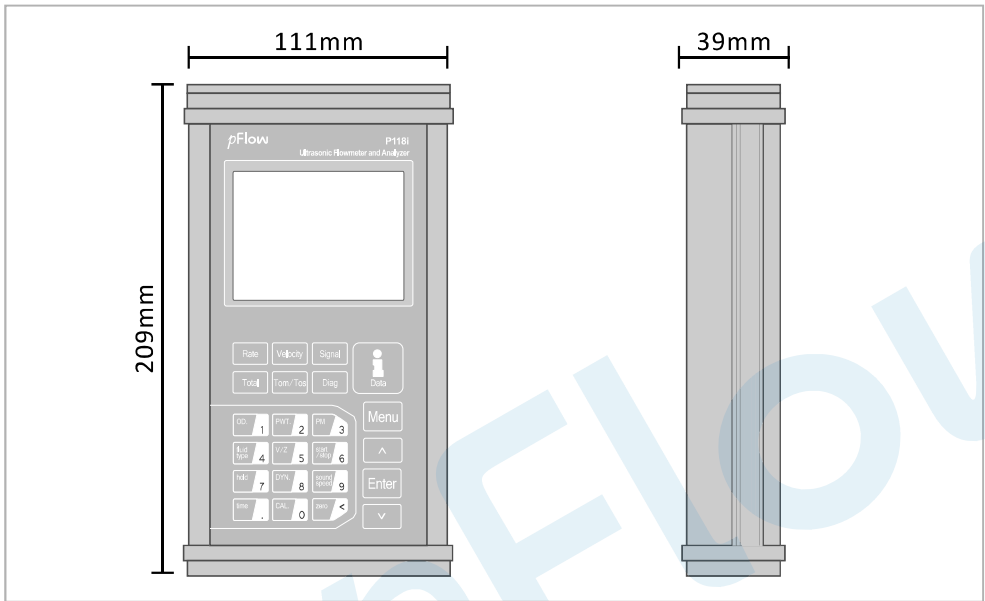

### Transducer

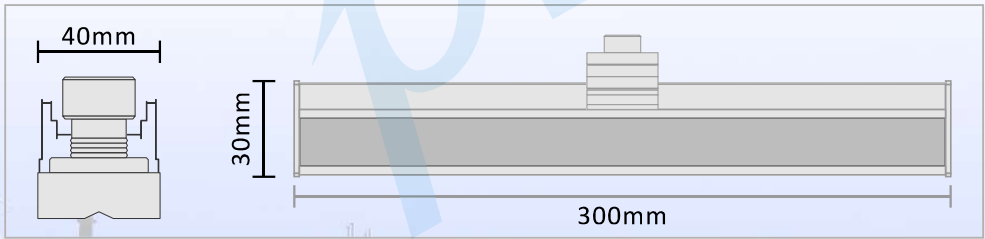

## Transducer Installation Methods

V method measuring pipe size : 50mm-400mm

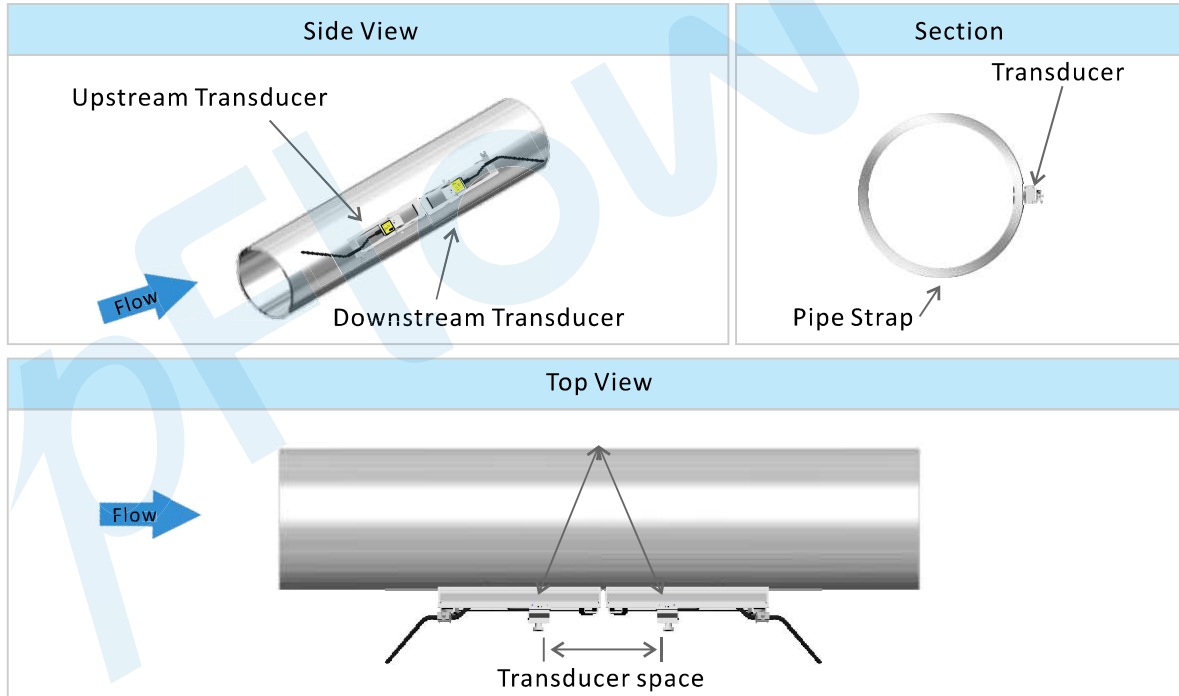

Z method measuring pipe size: 25mm-1200mm

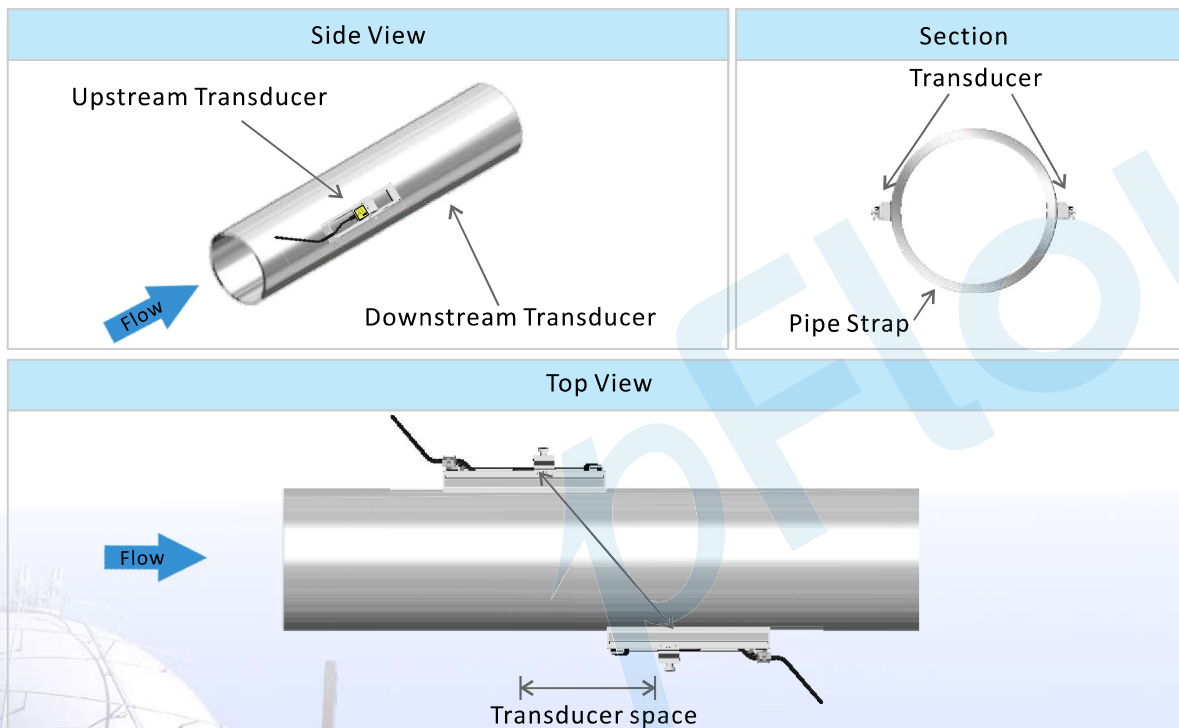



# Installation Site Selection

When selecting a measurement site, it is important to select an area where the fluid flow profile is fully developed to guarantee a highly accurate measurement. Use the following guidelines to select a proper installation site:

Choose a section of pipe that is always full of liquid, such as a vertical pipe with flow in the upward direction or a full horizontal pipe.

Ensure enough straight pipe length at least equal to the figure shown below for the upstream and downstream transducers installation.

Ensure that the pipe surface temperature at the measuring point is within the transducer temperature limits.

Consider the inside condition of the pipe carefully. If possible, select a section of pipe where the inside is free of excessive corrosion or scaling.

Straight length of upstream piping

Straight length of downstream piping

90° Bend

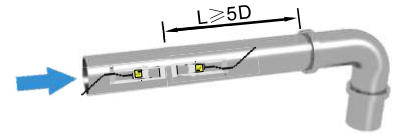
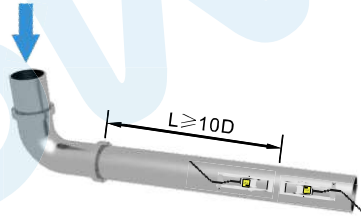

Tee

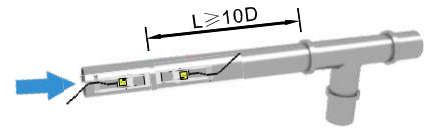
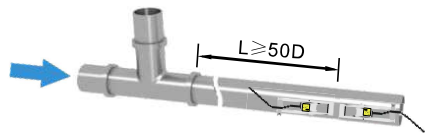

Diffuser

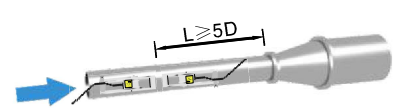
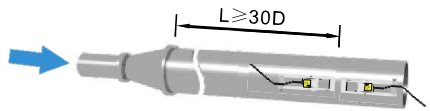

Reduce

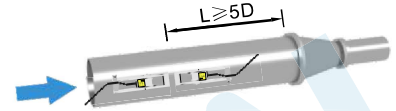
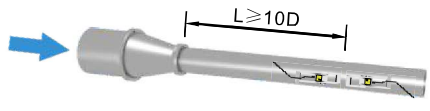

Valve

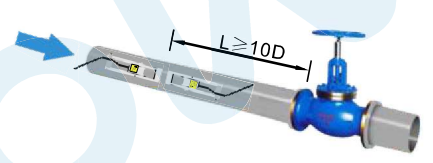
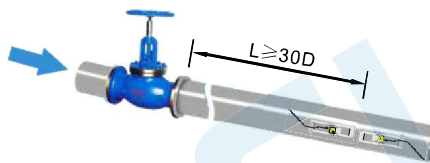

Vertical

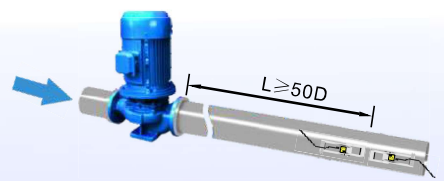
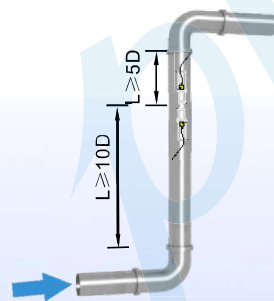

## Ordering Information

Description	
P118i	Handheld Ultrasonic Flowmeter Installation method: Handheld 2G SD card high memory data logging, maximum memorize 512 days data. Flow Range: $\pm 0.03$ ft/s $\sim$ $\pm 40$ ft/s ( $\pm 0.01$ m/s $\sim$ $\pm 12$ m/s) Accuracy: $\pm 0.5\%$ of measured value Repeatability: 0.15% Output: 4-20mA Internal lithium power supply: 10hours Pipe size range: 0.6"~240" (15mm~6000mm) Transducer: IP54, CP magnet portable transducer, 5m cable
Type of transducers	
P010	P type magnet portable transducer Operating temperature: 40°F~176°F (-40°C~80°C)
Transducer Cable Length	
016	P type of cable Standard 16ft (5m)
xx	Maximum lengthen to 30m, per 5m is a lengthen unit.
Standard Model: P118i-P010-016 Description: Portable transducers, 5m cable.	

## Packaging



- ① Carrying Case
- ② Transmitter
- ③ Transducer with scaled rack
- ④ Pipe Circles
- ⑤ Grease Coupling Compound
- ⑥ SD Card

## Product Line

### D116 Dedicated Ultrasonic Flowmeter



Accuracy:  
±1%

Flow range:  
0.03 ~ ±16ft/s

Pipe Size Range:  
1"~48"

### P116 Portable Ultrasonic Flowmeter



Accuracy:  
±1%

Flow range:  
0.03 ~ ±40ft/s

Pipe Size Range:  
1"~48"

### D118 Dedicated Ultrasonic Flowmeter



Accuracy:  
±0.5%

Flow range:  
0.03 ~ ±40ft/s

Pipe Size Range:  
1"~200"

### P118i Portable Ultrasonic Flowmeter



Accuracy:  
±0.5%

Flow range:  
0.03 ~ ±40ft/s

Pipe Size Range:  
0.6"~240"

### D118i Dedicated Ultrasonic Flowmeter



Accuracy:  
±0.5%

Flow range:  
0.03~±40ft/s

Pipe Size Range:  
1"~200"

### Application

Perfect performance in single liquid medium.  
Eg: Water, Pure water, Beer, Oil, etc.

Remark: The above mode choose doesn't including the spool piece, it is for customization.